

INSTALLATION INSTRUCTIONS

FOR LOTO TEC. PLUS LAMINATE FLOORING

GENERAL INFORMATION

READ THESE INSTRUCTIONS THOROUGHLY BEFORE BEGINNING INSTALLTION. If the following instructions leave any questions or if additional information is required, please contact us.

Loto Tec. Plus Laminate Flooring is a water-resistant product. Consideration for under structure or room quality and environment should always be given.

- Acclimation prior to installation is recommended. The product should be installed to intended service temperature between 68°F (20°C) - 86°F (30°C). or average temperature of 77°F (25°C) and a humidity range of 30%-50%. After proper acclimation, open cartons just prior to installation.
- Open room area should not to exceed 33 linear ft. (10m) in either direction or total of 1,089 sq. ft. (101 sq. m) with a 1/2" (12.7mm) expansion gap.
- The product replicates the look of a natural product which has natural variations in color and pattern. For the best visual effect, mix and install planks from several cartons and do not install similar planks next to one another.
- Appropriate underlayment is recommended to be used when installing over all hard surfaces.
- Do not install cabinets or kitchen islands on top of the product.

- Do not install Laminate Flooring in high-humidity areas where the floor is usually wet.
- The product is designed to be installed as an angle/tap installation. Careful consideration should be given when flat lay and tap close the end lock. This is necessary to avoid damage to profile.
- Install product after all other trades have completed work that could damage the flooring.

SUBFLOOR PREPARATION

Laminate Flooring is designed to be a floating floor. All subfloors should be flat to within 3/16" (5mm) in 10 feet (3 meters) radius for the best installation results.

CONCRETE SUBFLOORS

1. Concrete subfloors must be dry, smooth, and free from dust, solvent, paint, wax, grease, oil, asphalt sealing compounds and other extraneous materials. The surface must be hard and dense, and free from powder or flaking.
2. New concrete slabs must be thoroughly dry (at least six weeks) and completely cured.
3. All concrete slabs must be cured and tested for moisture. When conducting the calcium chloride test, moisture emission cannot exceed 8 lbs per 1,000 sq. ft. per 24 hours. Relative humidity not to exceed 85%.

Radiant Heat: Hydronic only Concrete floors with a hydronic radiant heating system is acceptable. The temperature of the concrete floor should not exceed 86°F (30°C) at any point. Before installing the flooring, the heating system should be turned on to eliminate residual moisture. Three days prior to installation, lower the temperature to 68°F (20°C). After installation, gradually increase the temperature in increments of 5°F to avoid overheating.

WOOD SUBFLOORS

1. All wood floors must be suspended at least 18" (457.2 mm) above the ground. Adequate cross-ventilation must be provided, and the ground surface of a crawl space must be covered with a suitable vapor barrier. Wood subfloors directly on concrete or installed over sleeper construction are not recommended.
2. The product can be installed over many wood substrates that are not suitable for fully adhered products, providing that they are smooth, flat, structurally sound and free of

deflection. Including particleboard, chipboard, flakeboard or OSB. Caution: wood panel subfloors may be damaged during construction. The suitability of these floors is the responsibility of the installer.

3. If the surface of the wood subfloor is not smooth, a 1/4" (6.4mm) underlayment panel must be installed over the subfloor. Any panels selected as an underlayment must meet the following criteria:

- Be dimensionally stable
- Have a smooth, fully sanded face so the graining or texturing will not show through
- Be resistant to both static and impact indentation
- Be free of any surface components that may cause staining such as plastic fillers, marking inks, sealers, etc.
- Be of uniform density, porosity and thickness
- Have a written warranty for suitability and performance from the panel manufacturer or have a history of proven performance

EXISTING FLOOR COVERINGS

Laminate Flooring can also be installed over most existing hard-surface floor coverings provided that the existing floor surface can be made smooth.

- Ceramic tiles should be well bonded, flat and even. Laminate Flooring can bridge up to 1/4" (6.4mm) in grout lines. If necessary, tiles can be made smooth using a cement-based patch or leveler.
- Existing floors should not be cushioned backed and not exceed one layer in thickness.
- Do not install over carpet.
- Floor should be flat, smooth and dimensionally sound, free from deflection.

INSTALLATION

Carefully examine the flooring prior to installation for color, finish, sheen, and quality. Ensure adequate lighting for proper inspection. If flooring is not acceptable, contact your supplier immediately. DDC FLOORS cannot accept responsibility for flooring installed with visible defects. Prior to installation of any flooring, the installer must ensure that the jobsite and subfloor meet the requirements of these instructions. DDC FLOORS is not responsible for a flooring failure resulting from unsatisfactory jobsite and/or subfloor conditions.

Room temperature and humidity of installation areas should be consistent with normal, year-round living conditions for at least one week before installation of flooring.

INSTALLATION TOOLS

Jamb Saw or Undercut Saw	Crosscut Power Saw	3M Scotch Blue™ 2080 Tape
1/2" (12.7mm) Spacers	Tape Measure	Rubber Mallet
Tapping Block	Chalk Line	Pencil
Circular or Radial Arm Saw with minimum 40 tooth carbide blade		Pull Bar

Floating Installation

Because houses and buildings, as well as adjacent hardwood or laminate floors, expand and contract, Laminate Flooring recommends leaving a 1/2" (12.7mm) expansion gap between the perimeter walls and any adjacent hardwood or laminate floors.

Begin installation next to an outside wall. This is usually the straightest and best reference for establishing a straight working line. Establish this line by measuring an equal distance from the wall at both ends and snapping a chalk line. The distance you measure from the wall should be the width of a plank. You may need to scribe cut the first row of planks to match the wall to make a straight working line if the wall is out of square. Measure the room at a right angle to the direction of the flooring. For the best visual effect, planks in the final row should be at least 1/3 the width of the plank. For this purpose, planks in the first row can be cut to smaller size.

You may want to position a few rows before starting installation to confirm your layout decision and working line. When laying flooring, stagger end joints from row to row by at least 8" (203 mm) for planks. For plank installations, you can use the cut-off end to begin the next row when cutting the last plank in a row to fit. If cut-off end is less than 8" (203 mm), discard it and instead cut a new plank at a random length (at least 8" in length) and use it to start the next row. Always begin each row from the same side of the room.



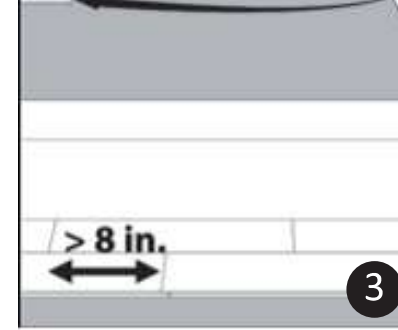
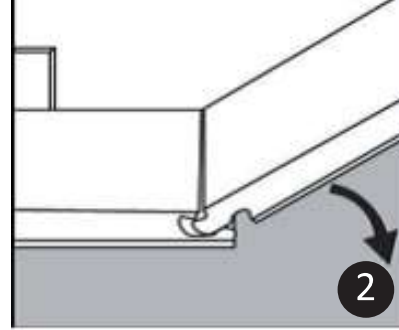
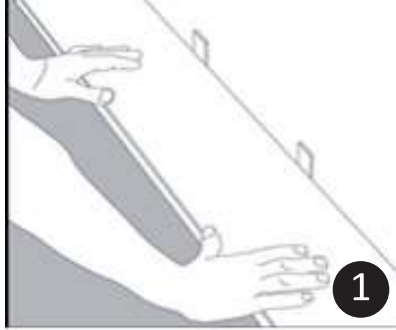

1: Begin installation working from left to right. Insert spacers at ends and edges where planks face wall.

2: Lock short end of plank by inserting tongue into groove at an angle and drop in place. Continue to end of first row.

3: Use leftover plank from first row as starter for second row. There must be at least 8" between plank end joints on adjacent rows.

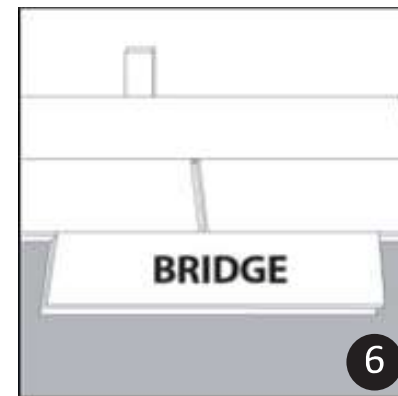
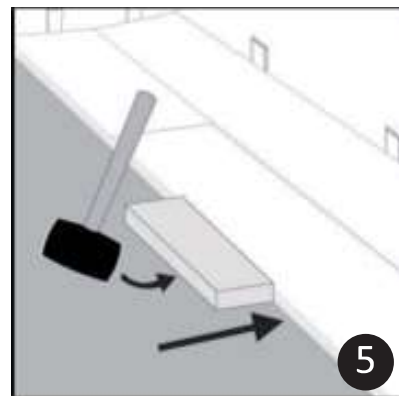
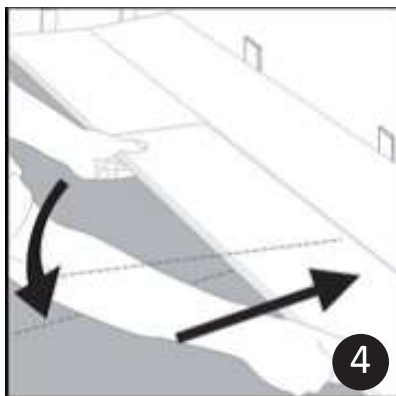

4: Lock long edge of plank by inserting tongue into groove at an angle and drop in place. Slide plank toward end of previously installed plank until the tongue just touches the groove.

5: Use rubber mallet and tapping block to tap long edge of plank to ensure a tight fit. Any gapping can compromise the locking system.

6: Attach a scrap piece of floor to bridge gap between ends of planks.



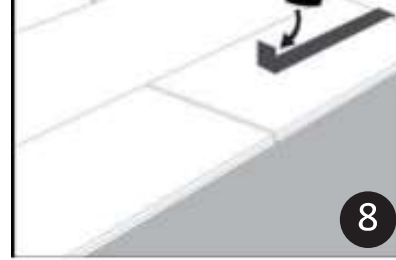
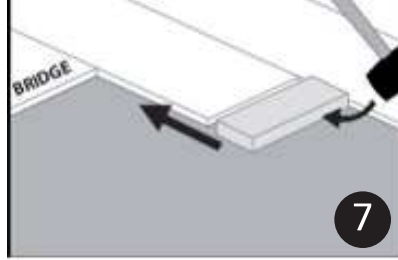

7: Tap end of plank with rubber mallet and tapping block to lock ends of planks together. Remove bridge and continue towards wall until installing the final plank in the row. Be sure to tap on edge of floor so as not to damage locking profile.

8: Use rubber mallet and pull bar to lock final piece in row. Insert spacer at end of row. Continue installation to final row.

9: Use rubber mallet and pull bar to lock long edges of planks on final row.

AFTER INSTALLATION

- In order to protect the floors while other trades are finishing their work prior to final cleanup and turnover to the owner, use rosin paper and only use 3M Scotch-Blue™ 2080 Tape to hold the rosin paper to the floor. Do not use plastic film or other nonbreathing coverings as this can cause increased humidity.
- Dust-mop or vacuum your floor to remove any dirt or debris.
- Furniture should be moved onto the newly installed floor using an appliance hand truck over hardboard runways.
- Use suitable non-staining and wide-bearing floor protectors under the legs of furniture.